

IntePlus[®] (XF Film) is produced by an exclusive patented process that includes the following three steps.

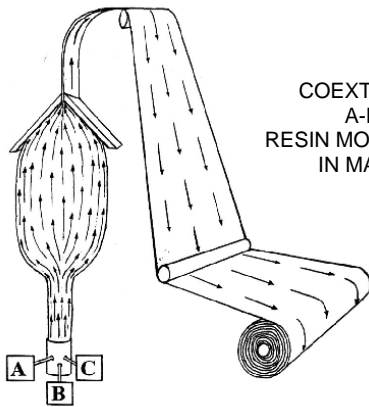

STEP 1
COEXTRUDED BLOWN FILM
A-B-C STRUCTURE
RESIN MOLECULAR ORIENTATION
IN MACHINE DIRECTION

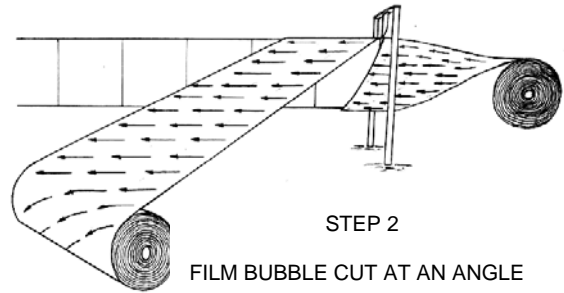

STEP 2
FILM BUBBLE CUT AT AN ANGLE

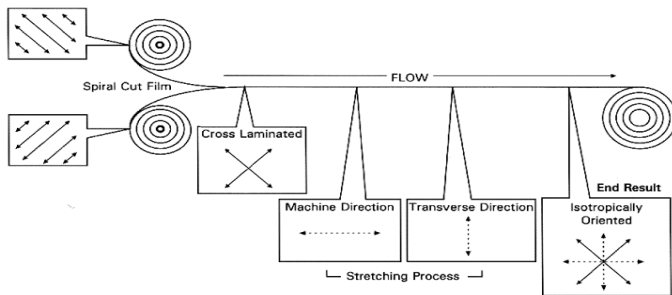

STEP 3
TWO OR FOUR LAYERS OF THE
SPIRAL CUT FILMS, WITH
ORIENTATIONS AT OPPOSITE
ANGLES, ARE LAMINATED TOGETHER